

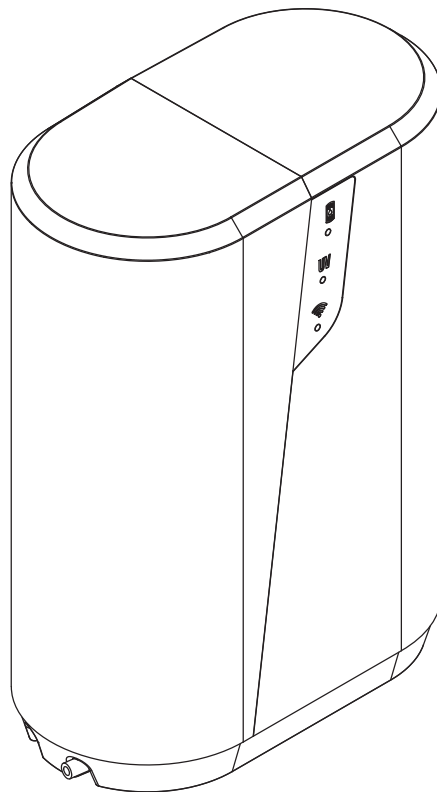

eSpring™

**Water Treatment System Mini Model**



Step 1: Unlock the left cover

Hold the lower part of the left cover, gently slide it to the left and lift. The left cover should come out with ease.

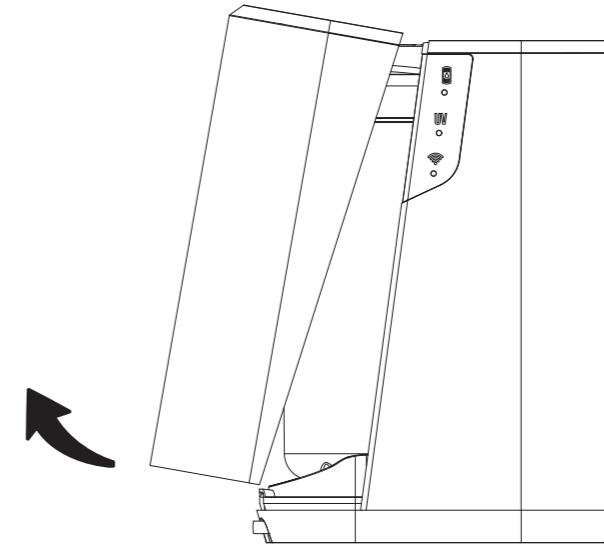

Step 2: Detach the water filter housing

Lift up the black handle until you hear a “click” sound.

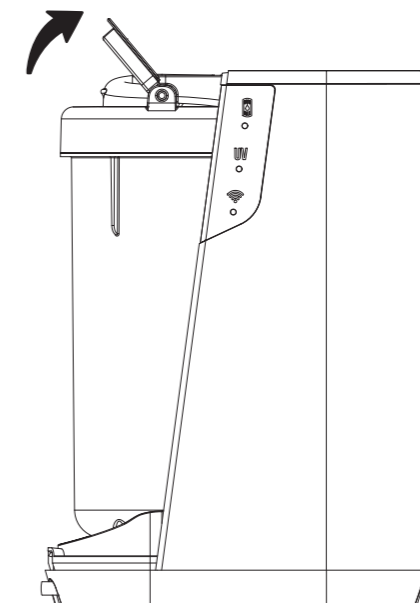

### Step 3: Remove the water filter housing

Tilt the top of the water filter housing to the left by 45° and lift the unit up and away.

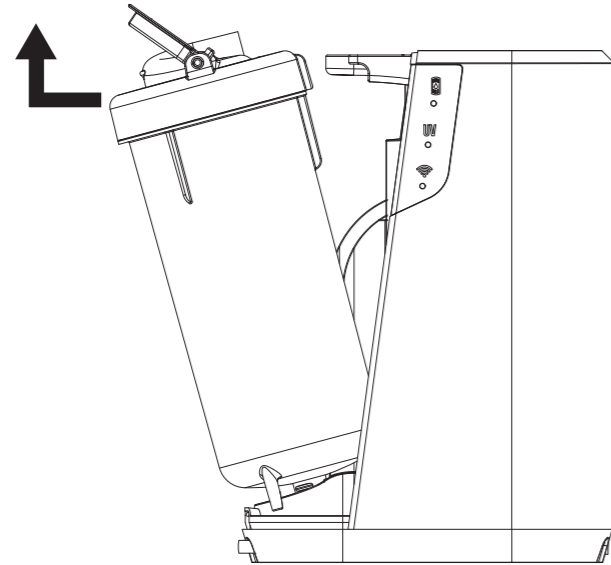

### Step 5: Remove the cover

Turn the cover clockwise and anticlockwise to loosen the tightly fitted cover, then pull the cover up and away from the replacement filter.

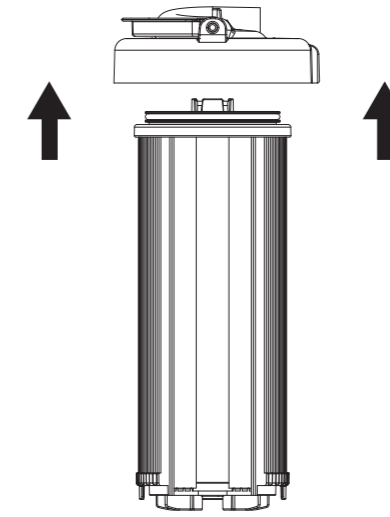

### Step 4: Remove the replacement filter

Hold the water filter housing tightly, then turn the cover anticlockwise by 180°. The replacement filter can easily be pulled out of the housing along with the cover.

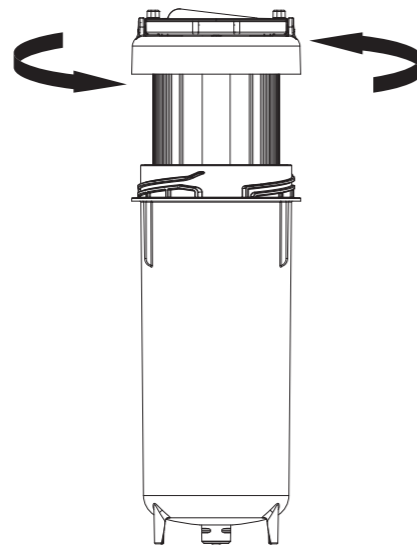

### For re-assembling the mini-model

Reverse the above steps: 3, 2, 1.

## Light switch

The sliding light switch is located on the base of the mini-model in black. One switch will turn on both the front indicator light panel and the UV-C water tank. Slide it right to turn on and slide it left to turn off.

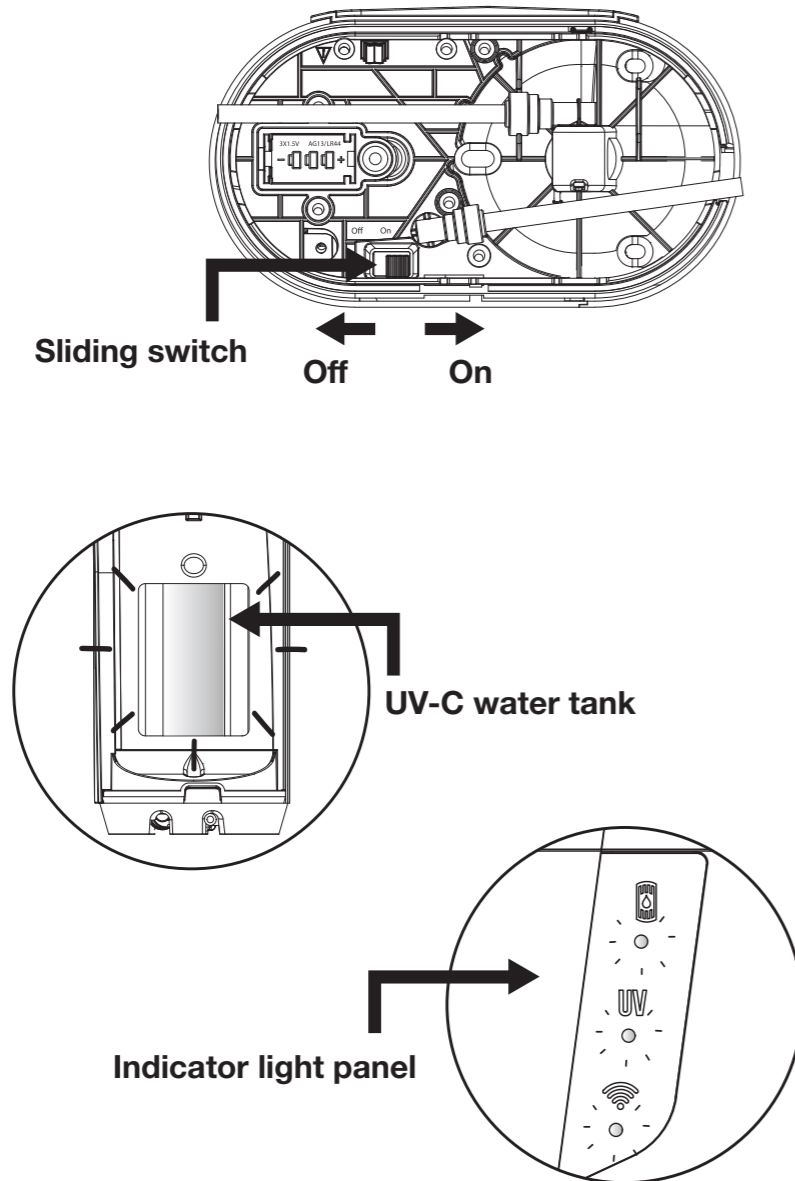

## Battery replacement steps

The battery compartment is located on the base. The mini-model requires 3 x AG13 button cell batteries. Please make sure that the correct batteries are inserted with the correct polarity.

1. Use a Phillips head screwdriver, and turn it anticlockwise to unlock the battery compartment cover.
2. Once the screw is fully unwound, use your fingertip to open the compartment cover.
3. Reverse the above steps 1 and 2 to lock the battery compartment cover.

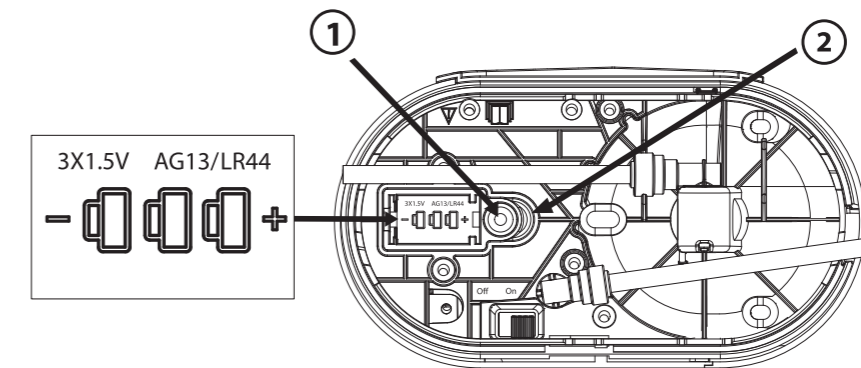

## WARRANTY

### WHAT DOES THIS WARRANTY COVER?

Amway warrants that the eSpring™ mini model will not prove defective (as defined below) under normal use for two (2) years from the date of original purchase. An item will be considered “defective” if it is defective in materials or workmanship and if the defect materially impairs the performance or value of the eSpring mini model to the original purchaser (the “Purchaser”).

### EXCLUSIONS

This Warranty does not cover:

- (a) Any eSpring mini model that has been subjected to any use that is different than or inconsistent with the use instructions in the eSpring mini model Owners Manual.
- (b) Any eSpring mini model that has been subjected to any abuse, accident, physical damage, improper application, alteration, neglect, improper temperature, humidity or other environmental conditions (including, but not limited to, lightning, flood or fire).
- (c) Any eSpring mini model that has been damaged due to improper repair, modification, alteration or maintenance by anyone other than an authorized service warranty representative of Amway.

### USE OF NON-AUTHORIZED PARTS OR ACCESSORIES

The use of replacement parts or accessory attachments not recommended by the manufacturer may result in diminished performance. Amway does not warrant the performance of any non-eSpring mini model parts or accessories, and is not responsible for any damage to the eSpring mini model caused by any non-eSpring mini model parts or accessories.

### RIGHTS OF THE PURCHASER

If any eSpring mini model that has not been subjected to any abuse, accident, physical damage, improper application, alteration, neglect, improper temperature, humidity or other environmental conditions (including, but not limited to, lightning, flood or fire) proves to have been defective, Amway will, at Amway’s option, either repair or replace the defective item at its expense, or refund an appropriate part of the price of the item to the Purchaser.

### CLAIM

For service under this Warranty, please contact Customer Service, BEFORE you return anything, for failure diagnosis, shipping and handling instructions.

In order to make a claim under this Warranty, the Purchaser must notify Amway of the defect, in writing, after having called Amway in advance, within two (2) months after the defect has been discovered, but in all events no later than two (2) months after the end of the applicable warranty period.

The Purchaser must provide proof of purchase, i.e. the invoice for the eSpring mini model or other proof of purchase. Upon receipt of an eSpring mini model that is claimed to

be defective, Amway will determine, at its reasonable discretion, whether the eSpring mini model is defective. If model is defective, Amway will bear the expense of shipping, both ways, with respect to replacement of any defective eSpring mini model within the Warranty period. If, in Amway’s opinion, the eSpring mini model is not defective, it will be returned to the Purchaser.

### LIMITATIONS

Unless otherwise required under European Union and national laws, this Warranty sets forth the Purchaser’s sole and exclusive remedies for any defect in the eSpring mini model.

Unless otherwise required under European Union and national laws, THE WARRANTIES STATED HEREIN ARE IN LIEU OF ALL OTHER WARRANTIES, EXPRESS, IMPLIED, STATUTORY OR OTHERWISE, EXCEPT FOR THE IMPLIED WARRANTY OR CONDITION OF MERCHANTABILITY, THE IMPLIED WARRANTY OR CONDITION OF FITNESS FOR A PARTICULAR PURPOSE, AND ANY OTHER NON-DISCLAIMABLE WARRANTIES IMPOSED BY EUROPEAN UNION AND NATIONAL LAWS. NO SUCH NON-DISCLAIMABLE WARRANTY, INCLUDING BUT NOT LIMITED TO THE IMPLIED WARRANTY OR CONDITION OF MERCHANTABILITY AND THE IMPLIED WARRANTY OR CONDITION OF FITNESS FOR A PARTICULAR PURPOSE, SHALL BE FOR TERMS EXTENDING BEYOND THE DURATION OF THE EXPRESS LIMITED WARRANTY DESCRIBED ABOVE.

Notwithstanding the foregoing, some legal jurisdictions do not allow limitations on how long an implied warranty lasts, so the above limitation may not apply to you.

Insofar as it is permitted under European Union and national laws, Amway accepts no liability for incidental or consequential damages. Some legal jurisdictions do not allow the exclusion of incidental or consequential damages, so this exclusion may not apply to you.

This Warranty does not affect the Purchaser’s statutory rights under applicable national laws in force.

Unless otherwise required under European Union and national laws, no person is authorized to modify or expand the Warranty provided herein, waive any of the conditions and limitations of this Warranty, or make any different or additional warranties with respect to the eSpring mini model. Any statements to the contrary shall be of no effect unless made in writing and signed by an authorized representative of Amway.

For further details please contact your Amway Business Owner\* or call your Customer Service center.

### NINETY (90) DAY SATISFACTION GUARANTEE

In addition to the warranty, you, the original user, have the right to use the eSpring mini model for ninety (90) days from the date of the purchase to determine if it is satisfactory and you want to keep it. If, within such ninety (90) day period, you decide it is not satisfactory, you may return it to the Amway Business Owner\* from whom you purchased it. The Amway Business Owner\* will offer you the choice of replacement without charge, or full credit toward the purchase of another Amway product, or a refund for the full purchase price.

\* Amway Business Owner is called Amway Independent Business Owner in Australia and New Zealand.

Customer Service telephone numbers: / Телефонни номера за обслужване на клиенти: / Telefonní čísla na Kontaktní centrum: / Telefonnummern des Contact Center: / Klienditeeninduse telefoninumbrid: / Τηλέφωνα Εξυπηρέτησης Πελατών: / Números de teléfono del Centro de Contacto: / Numéros de téléphone du Service Client : / Telefonski brojevi Odjela za odnose sa strankama: / Numeri di telefono del Servizio Assistenza Clienti: / Klientu apkalpošanas dienesta tālruna numuri: / Klientų aptarnavimo centro telefono numeriai: / Az Ügyfélszolgálat telefonszámjai: / Telefoonnummers van de Klantenservice: / Numery telefonów Centrum Kontaktu z Klientem: / Números de telefone do Serviço de Apoio ao Cliente: / Numerele de telefon ale Serviciului Relații cu Clienții: / Telefónne číslo zákazníkneho oddelenia: / Telefonske številke oddelka za stike s strankami: / Amway Müşteri Hizmetleri İletişim Merkezi: / Телефони Інформаційної служби:

Ⓐ +43 1 206 091 612

Ⓑ +32 2 200 89 07

Ⓒ +359 3 25 71 797

Ⓓ +41 22 7614 124

Ⓔ +420 239 018 075

Ⓕ +49 89 800 94 450

Ⓖ + 372 8 84 00 75

Ⓗ +34 910 50 75 20

Ⓙ +331 57 32 44 73

Ⓚ +30 2 11 19 87 671

Ⓛ +385 800 791161

Ⓜ +36 1 77 77 667

Ⓝ +353 1 562 11 87

Ⓘ +39 02 87 10 36 03

ⓁⓉ + 370 5 214 2773

ⓁⓋ +371 6 60 90 527

ⓃⓁ +3120 203 53 82

Ⓟ +48 2 230 622 53

ⓅⓉ +351 2 14 70 44 00

ⓇⓄ +40 3 737 882 32

ⓈⓀ +421 2 686 226 31

ⓈⓁ +386 1 584 41 00

ⓉⓇ +90232 455 4444

Ⓤⓐ +38 044 495 13 00

ⓊⓀ +44 20 36 842 540

ⓐⓊ 1800 45 46 47

ⓃⓏ 0800 611 611

Ⓢⓐ 011 201 4400